

PGR-8800 SERIES

Arc-Flash Relay

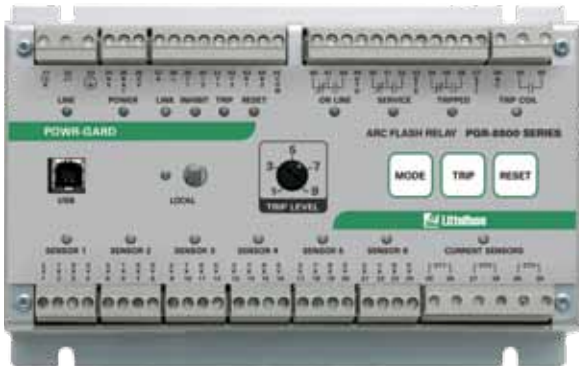

Description

The PGR-8800 is a microprocessor-based relay that limits arc-fault damage by detecting the light from an arc flash and rapidly tripping. Phase-current-transformer inputs are provided for current-constrained arc-flash protection and, when so equipped, a programmable definite-time overcurrent function can be enabled. An optical sensor on the PGR-8800 and adjustable trip level reduce the chance of nuisance tripping by setting a threshold for ambient light. Sensors, inputs, and connections are monitored to ensure fail-safe operation. A secondary solid-state trip circuit provides a redundant trip path. A USB port is used for configuration and access event logs and graphs.

Simplified Circuit Diagram

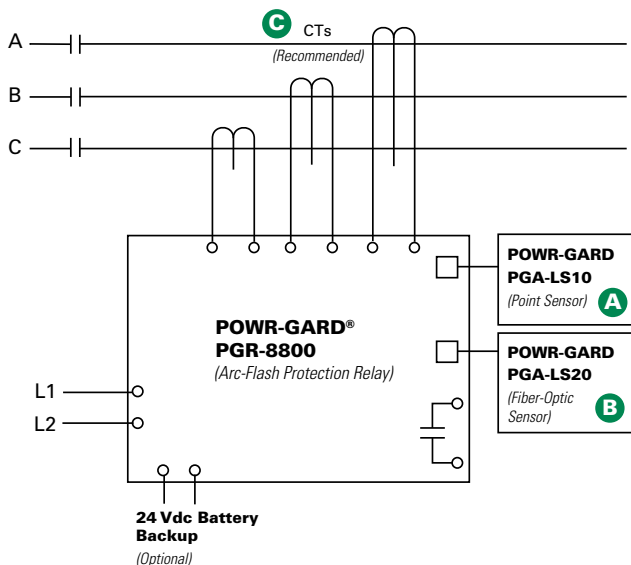

Optical Sensors

The PGR-8800 accepts both PGA-LS10 and PGA-LS20 optical sensors designed to collect light over a wide angle and with high sensitivity. For fast fault location, front-panel and sensor LED's indicate sensor health and which sensor detected an arc fault.

Sensor Placement

The PGR-8800 Arc-Flash Relay and sensors are easily installed in retrofit projects and new switchgear with little or no re-configuration. Even elaborate systems with multiple power sources take minutes to configure using the relay's built-in USB interface software.

Generally, it is recommended to mount 1 or 2 sensors per cubicle to cover all horizontal and vertical bus bars, breaker compartments, drawers, and anywhere that there is potential for an arc-fault. Threading a fiber-optic sensor through the cabinets and in areas where point-sensor coverage is uncertain results in complete coverage and an added level of redundancy. Even if policy is to only work on de-energized systems, all maintenance areas should be monitored to prevent potential damage and additional cost. At least one sensor should have visibility of an arc fault if a person blocks the other sensor(s).

Ordering Information

CATALOG/ SYSTEM NUMBER	COMMUNICATIONS
PGR-8800-00	Multi-unit linking, USB

ACCESSORIES	REQUIREMENT	PAGE
PGA-LS10	Required*	52
PGA-LS20	Required*	52
Current Transformer	Recommended	49

*At least one sensor is required. However, the exact number of sensors for proper coverage depends on the application.

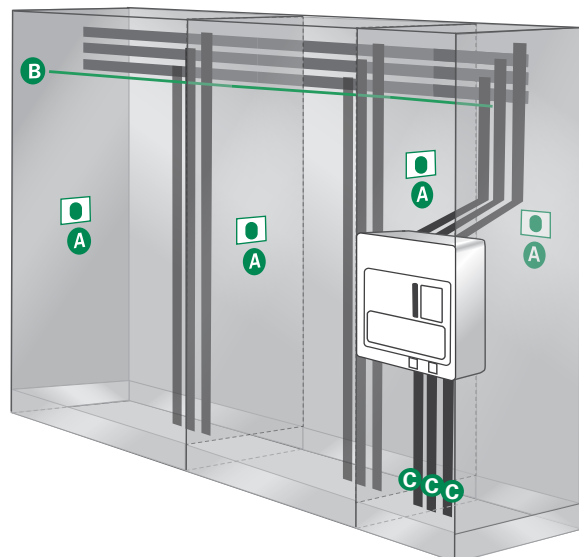



Features & Benefits

FEATURES	BENEFITS
Arc-Flash Trip Time <1 ms	Limits arc-flash damage and risk of injury
Multiple Sensors (up to 24)	Single module can monitor 6 sensors. Up to 4 PGR-8800 units can be linked into one system
Fail-Safe System	Continuous monitoring of optical sensors and inputs ensures protection
Redundant Trip Circuit	Solid-state backup arc-detection circuit adds a second layer of safety
Adjustable Light Sensitivity	Allows for operation in bright environments and maximum sensitivity in dark environments
LED Indication (on unit and each sensor)	18 LEDs provide at-a glance status for module and I/O state
Current Detection	Phase-CT inputs provide overcurrent protection and prevent nuisance trips
Optical Detection	Point and fiber-optic sensors provide wide detection area with sensor health trip indication
Digital Inputs (6)	Two each: remote trip, inhibit, and reset inputs
Service Mode	Allows for system test without tripping
Trip Coil Contact	Solid-state 24-600 Vdc/24-440 Vac IGBT
Indication Contacts	Form C and status outputs
USB Interface	Data logging and configuration software uses a USB interface with no drivers or software installation
Built-in Sensor	Can be used in single-sensor systems, as a seventh sensor, and for calibration
Universal Power Supply/Battery Backup	100-230 Vac, 12-60 Vdc, or 100-250 Vdc supply accepted. Ability to charge and run off an external, user-supplied 24 Vdc battery.
Data Logging	On-board 1000-event recorder helps with system diagnostics

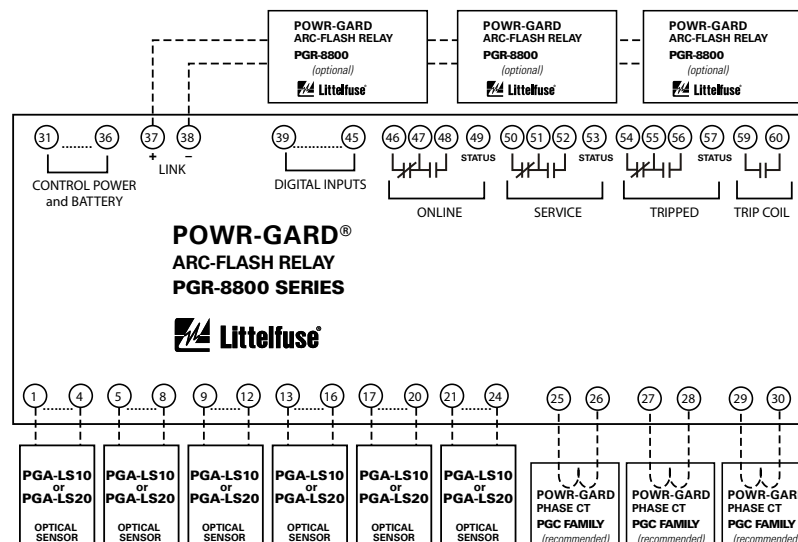
Wiring Diagram



Accessories

- A**  **PGA-LS10 Point Sensor**
 Line-of-sight light sensor detects an arc as small as 3 kA within a 2-m half-sphere. Sensor health and trip indication.
- B**  **PGA-LS20 Fiber-Optic Sensor**
 360° light sensor for tricky installations with many shadows or to run along bus bars. Sensor health and trip indication.
- C**  **Current Transformers**
 Eliminate nuisance arc-flash trips and use for overcurrent protection.

Specifications

IEEE Device Numbers	Overcurrent (50), Arc Flash (AFD)
Input Voltage	100-230 Vac, 12-60 Vdc, and 100-250 Vdc
Dimensions	H 130 mm (5.2"); W 200 mm (7.9"); D 54 mm (2.2")
Optical Trip Settings	10-40 kLux, 300 μ s-2 s
Current Trip Setting (A)	Programmable
Indication Contact Mode	Fail-safe
Trip Coil Contact Mode	Selectable fail-safe or non-fail-safe
Redundant Trip Circuit	Standard feature
Input Monitoring	Standard feature
USB Interface	Standard feature
Trip, Reset, Service Buttons	Standard feature
Expandable System	Link up to 4 PGR-8800 units
Certification	CE
Warranty	5 years
Mounting	DIN, Surface